

# ACCU-PAK 4-IN-1

 **WASTEQUIP  
ACCURATE**

**MODELS  
D-600  
D-800**

 **WASTEQUIP  
ACCURATE**  
★ PROUDLY MADE IN THE USA ★

U.S. Patent No. 5,752,439



- **FIELD CONVERTIBLE**
- **UNIQUE ALL DIRECTION FEED CAPABILITY**
- **4-IN-1 VERTICAL COMPACTION SYSTEM**



**REDUCE SOLID WASTE HANDLING COSTS with WASTEQUIP COMPACTOR SERIES**

***WasteQuip Accurate's 4 in 1 ACCU-PAK is an All Purpose Self Contained Compactor  
Specifically Engineered and Designed for  
Restaurants, Motels, Fast Food, Grocery Stores and Apartment Complexes  
with Limited Installation Space.***

*Manufacturing Compaction Equipment Since 1973*

**WASTEQUIP ACCURATE FOCUSING ON CUSTOMER SATISFACTION**

# "ACCU PAK" SPECIFICATIONS

## REAR FEED

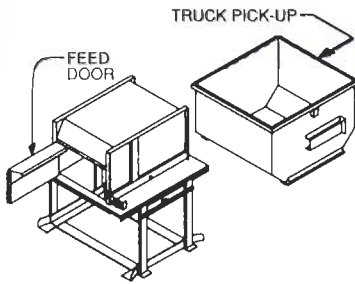

## FRONT FEED

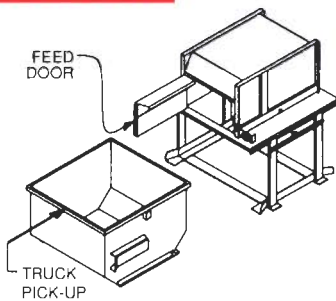

## LEFT FEED

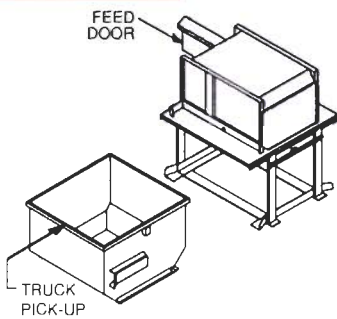

## RIGHT FEED

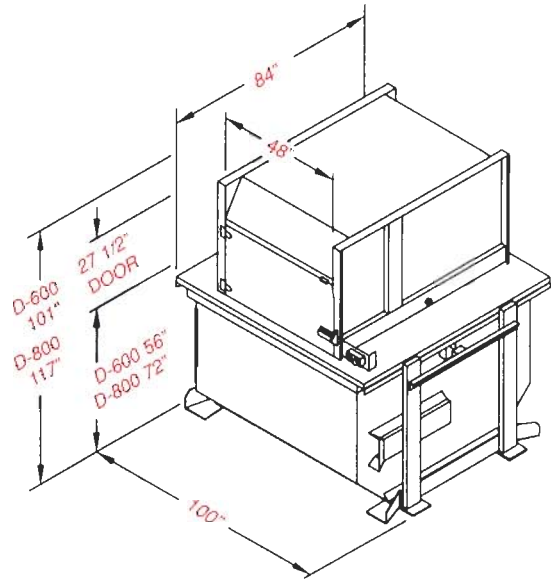
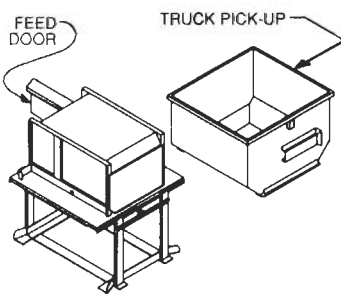

## STANDARD FEATURES

**Electric Components:** U.L. Approved;  
Locally Available

**Energy Efficient Tri-Voltage Motors**

**Hydraulic Parts:** JIC Approved;  
Locally Available

**Hydraulic Power Unit:** Integral Power Unit

**Key Operated Start Switch:** Multi-Position,  
Unit Mounted with 15' Sealtite

**Lights:** Container Full Indicator Light  
Container In Position Light

**Switches:** Dual Purpose, Pressure  
Activated for Auto-Cycling  
and Container Full

**Valves:** Directional Solenoid and Relief Valves

## GENERAL SPECIFICATIONS

**Control Circuit:** 110 volts

**Cycle Time:** 20 seconds

**Motor:** 5HP / 1800RPM T.E.F.C.  
208/230/460/3 phase, 60Hz

**Ram Cylinder:** 4.0" Bore, 2.0" Rod

**Ram Force:** 28,300# normal

**Ram Penetration:** 18"

**Ram Stroke:** 16"

**Reservoir:** 7 gallons

**System Pressure:** 2250 PSI, Factory Set

**Weight:** Basic Unit - D600=3500#  
D800=3740#

*Note: For complete Accu-Pak specifications, consult factory representative.*

*Unless stated otherwise in writing, container sizes indicated on sales literature, invoices, price list, quotations and delivery tickets are nominal sizes. Actual volume may vary from nominal sizes.*

## OPTIONS AVAILABLE:

- Chute Extension
- Loading Platform with Safety Rail
- Through-the-Wall Installation
- Thermostat Controlled Oil Heater
- Special Paint or Color Scheme
- Automatic Odor Suppression System
- Installation and Set-Up
- Extended Warranty and Service Contract

**WINTER EQUIPMENT CORP**  
614 FLORENCE ST  
COLUMBIA, PA 17512

Toll Free: 800-472-4250  
Phone: 717-681-0085  
Fax: 717-681-0055

Authorized Distributor:



Printed On  
Recycled Paper